

2024 ALL-NEW



SCARLET | TECH

# TWL-1SV

## Online Heat Stress Weather Station

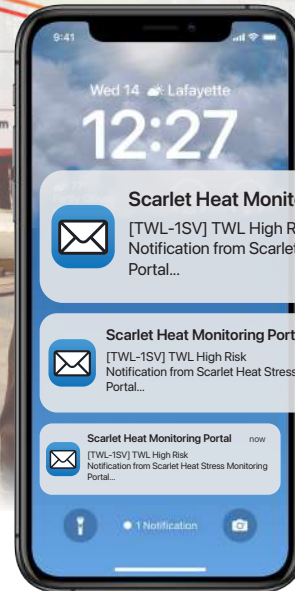
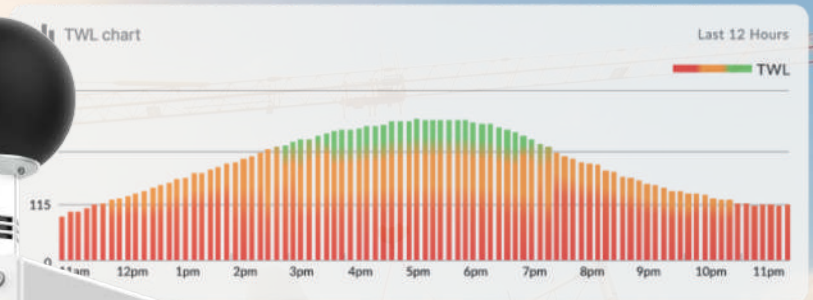

- Measure TWL, WBGT, Heat Index
- Remote real-time monitoring
- Access & download all data on web portal
- Get instant heat stress alerts via web or email
- Gather all data on a private cloud platform
- Ensure OSHA compliance for heat safety

# The Online Solution for Heat Monitoring

TWL-1SV is an advanced heat stress weather station designed to enhance heat safety and enable remote management. It uses TWL and WBGT algorithms to calculate heat stress indices from ambient temperature, humidity, radiant heat, wind speed, and direction. Users can access real-time heat measurements online, download historical data, and receive instant alerts via browser and email.



## Real-Time Data

Dynamic calculations of thermal work limit (TWL), wet bulb globe temperature (WBGT), and heat index (HI).



## Instant Alert

Receive TWL alerts from all TWL-1SV stations via browser or email notifications.



## Intuitive Display

All heat indices and hydration plans are displayed in intuitive tables and charts.



## Data Logging

Access all sensor data and events stored in cloud storage for long-term monitoring and analysis.

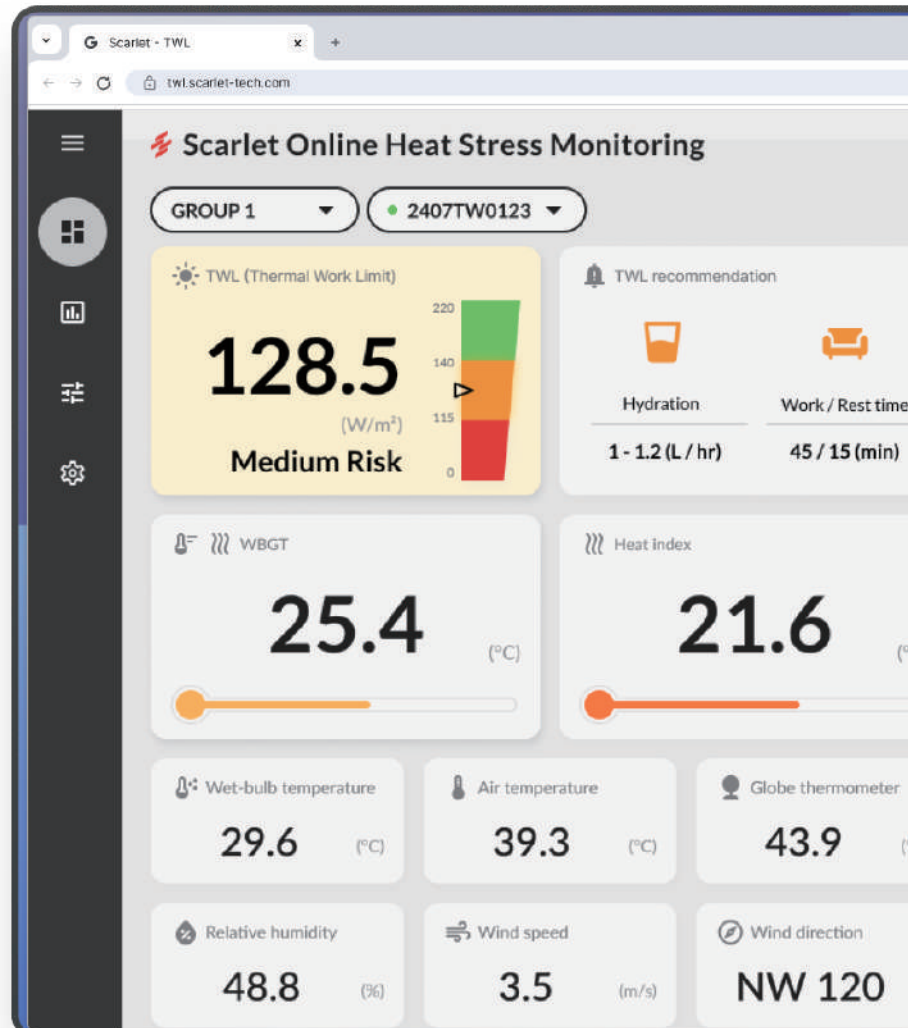

# TWL-1SV Weather Station Overview

TWL-1SV is equipped with ultrasonic wind and black globe temperature sensors. Designed for hassle-free installation and compact in size, this heat stress weather station can withstand outdoor conditions with an IP67 waterproof rating. The TWL-1SV begins data output within 2 minutes of powering on, operates on AC power, and features an SD card for convenient data logging backup. Additionally, it includes a tripod for quick deployment across different landscapes.



## Ultrasonic Wind Sensor

- **Air temperature & humidity**  
Assessing ambient temperature and moisture content in the air.
- **Wind speed & direction**  
Monitoring wind speed and direction even in low-wind conditions.

## Black Globe Temperature Sensor

Measuring accurate radiant heat temperature of the environment.

## Connectivity

- **LAN**  
Provides internet connectivity to the cloud portal through the RJ45 connector.
- **Serial**  
Accesses data using serial commands via MODBUS/RS232 parameters.
- **Power Supply**  
Ensures reliable operation with a 100-240V power adapter.
- **Bluetooth**  
Viewing data nearby and configure with ease.

## IoT-Driven Heat Safety Solution

Heat indices are measured on the TWL-1SV device and directly transmitted via Ethernet to the cloud portal. Users can easily access real-time and historical data on Scarlet's web portal.



# Cloud-Based Heat Monitoring Web Portal

Scarlet Online Heat Monitoring Web Portal displays heat indices and weather factors measured by TWL-1SV, providing real-time data and visual alerts. With the web portal, user can remotely monitor multiple TWL-1SV stations, ensuring comprehensive heat management from any location.

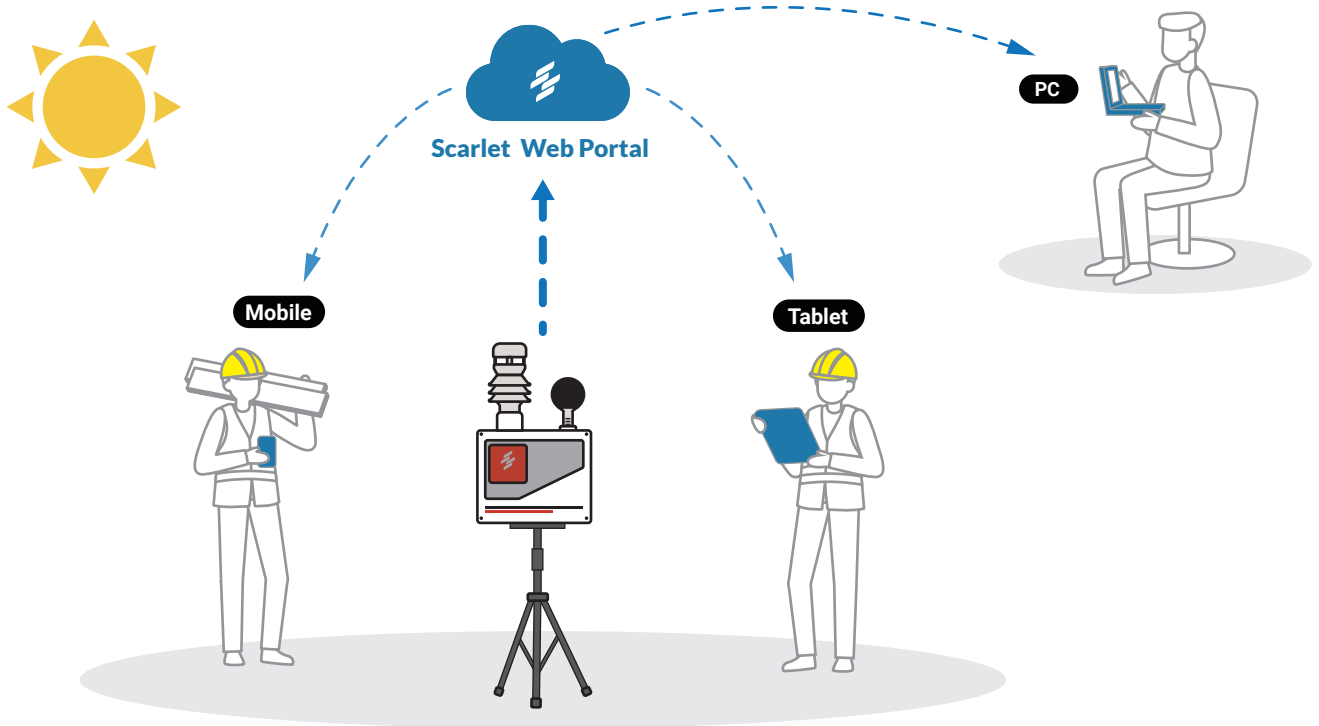

## Instant Alert on Your Smart Device

Access TWL-based heat alerts through the cloud portal, ensuring users receive notifications via browser or email from any location. On-site HSE officers can monitor TWL levels directly on their mobile devices, even when attending to other tasks. Meanwhile, higher management can monitor worksite heat stress status remotely.



Phone



Tablet



PC



## Understand TWL in 10 Seconds

Thermal Work Limit (TWL) index is primarily designed to calculate the maximum metabolic rate to evaluate the risk of heat stress in workplaces. TWL calculates factors such as air temperature, humidity, radiant heat, and wind speed. It provides instructions for work-rest cycles and hydration plans in heat-intensive areas.

(TWL > 140)

(115 < TWL < 140)

(TWL < 115)



TWL-1S utilized for heat risk assessment at worksite in Abu Dhabi.



# Specifications

## • Heat stress index

Wet-bulb temperature	Operating range: 0 to 66 °C
	Resolution: 0.1 °C
Wet-bulb globe temperature (WBGT)	$WBGT = 0.7 \times Tw + 0.2 \times Tg + 0.1 \times Ta$
	Resolution: 0.1 °C
Thermal work limit (TWL)	Dynamic calculation based on Tw, Tg, Ta and WS
	Safe max < 38.2 °C
Heat index (HI)	Operating range: 0 to 66 °C
	Resolution: 0.1 °C

## • Environmental sensor

Globe thermometer	Operating range: 0 to 80 °C
	Accuracy: ±1.5 °C (15 to 40 °C); ±2.0 °C (others)
	Resolution: 0.1 °C
Dry-bulb temperature	Operating range: -40 to 80 °C
	Accuracy: ±0.5 °C
	Resolution: 0.1 °C
Humidity	Operating range: 0 to 100 % RH
	Accuracy: ±2%
	Resolution: 0.1%
Wind speed	Operating range: 0 to 40 m/s
	Accuracy: ±5%
	Resolution: 0.1 m/s
Wind direction	Operating range: 0 to 359° (no blank sector)
	Accuracy: ±3°
	Resolution: 1°

## • System

Power supply	100 to 240 Vac Power adapter
Measurement frequency	1 Hz block average to a programmable output frequency, factory set to 2 min
Internet connection	Ethernet via RJ45 connector (Default)
	4G LTE (Optional)
Configuration method	Mobile app via bluetooth pairing
Memory	Build-in SD card;
	Backup storage for cloud connection lost
Output connectivity	Modbus /RJ45; Windows IIS API
Degree of protection	IP65 water protection
Device dimension	32 x 52 x 13 cm
Tripod dimensions	6.5 x 12 x 61 cm (Folded)
	46 x 12 x 108 cm (Extended)
Weight	8.5 kg (18.7 lb) with tripod

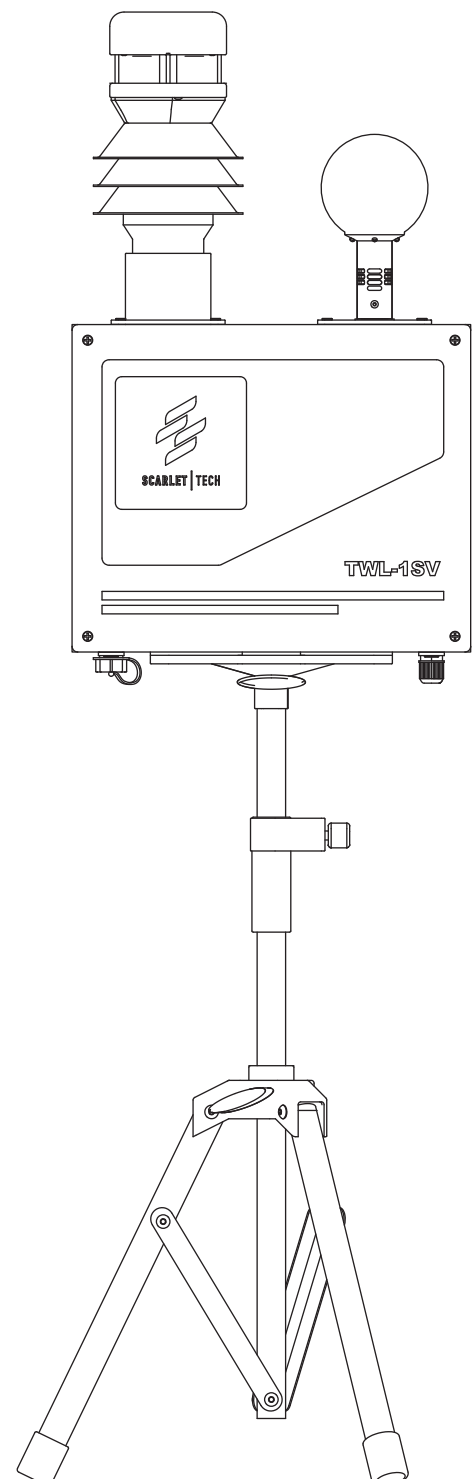



Scarlet Tech Co., Ltd.  
© 2015 Scarlet Tech Co., Ltd. All rights reserved.  
4F-3, No. 347, HePing E Rd, 2nd Sec, DaAn District, Taipei City 106, Taiwan  
info@scarlet.com.tw  
www.scarlet-tech.com

version 240903